

ATOMSTACK Dustproof Safety Protection Enclosure

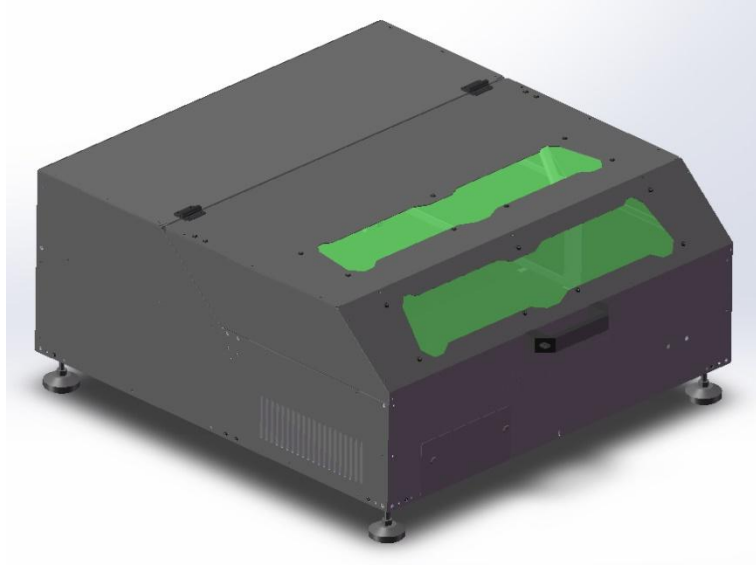

Note: The picture is for reference only, the actual product shall prevail.

For the installation video tutorial and other information, please scan the QR code.

- English
- Deutsche
- Français

F03-0036-0AA1 Version: B











Laser Engraver

Pre-installation instruction:

1. Total 31 sheet metal components of the protective cover, details in the table. All parts are pasted with serial number stickers.

Accessories: acrylic board 2PCS, foot pad 4 PCS, support rod 2 PCS, Support rod fixing block A 2PCS, Support rod fixing block B 2PCS,LED strip 1 PC, handle 1PC, fan component 1 set.Confirm quantity before installation.

1#	2#	3#	4#	5#	6#	7#	8#	9#
1 PC	1 PC	1 PC	1 PC	4 PCS	1 PC	1 PC	1 PC	1 PC
10#	11#	12#	13#	14#	15#	16#	17#	18#
1 PC	1 PC	2 PCS	2 PCS	2 PCS	1 PC	1 PC	1 PC	1 PC
19#	20#	21#	22#	23#	24#	25#		
1 PC	1 PC	1 PC	1 PC	1 PC	1 PC	1 PC		

Acrylic board	Foot pad	Support rod	Support rod fixing block A	Support rod fixing block B	LED strip	Handle	Exhaust fan
							
2 PCS	4 SETS	2 PCS	2 PCS	2PCS	1PC	1 PC	1 SET

M3*6	M3*8	M4*8 M4	M5*14 M5	M5*14 M5	M5*14 M5	M4*8 M4
						
160 PCS	10 PCS	Screws: 14 pcs Nut: 14 pcs	Screws: 2 pcs Nut: 2 pcs	Screws: 3 pcs Nut: 1 pcs	Screws: 3 pcs Nut: 1 pcs	Screws: 4 pcs Nut: 4 pcs
M3*6 M3	Power Adapter	Adapter cable	Wrench		Cable Ties/Square Buckle	
						
Screws: 6 pcs Gasket: 6 pcs	1 PC	1 PC	H3 : 1 pc H2.5: 1 pc H2: 2pcs, 8# and 10#: 1pc; 6# and 7#: 1pc		Cable Ties:3pcs Square Buckle:3pcs	

2. The following is the approximate sequence of assembly.

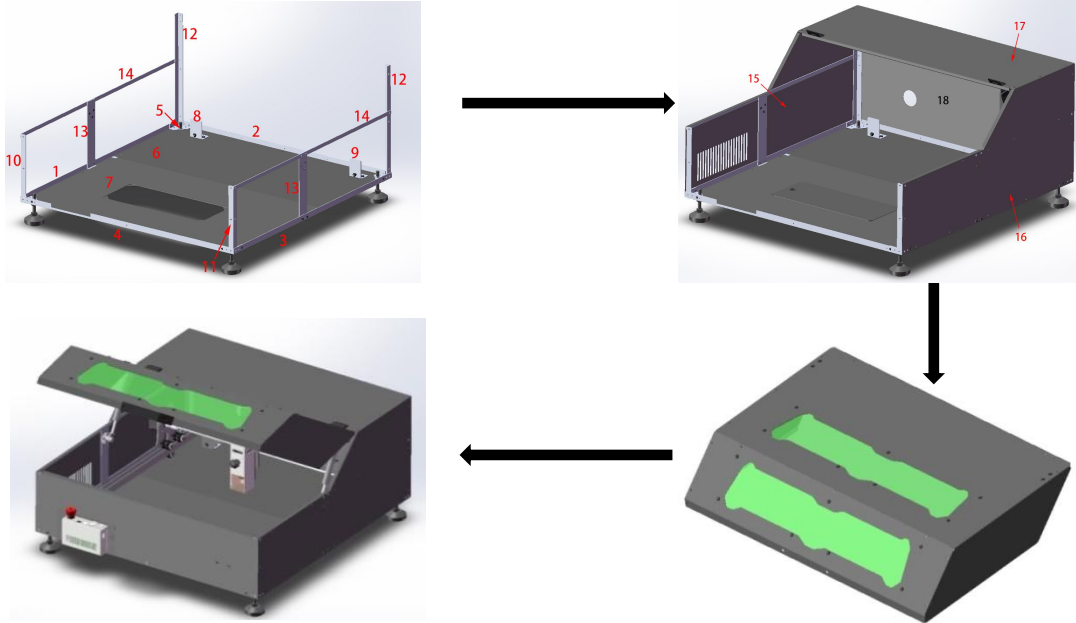

3. During the mounting, do not tighten the screws first. May you first insert the diagonal 4 screws when mounting a metal plate, then followed by inserting all screws. Tighten all the screws when the final adjustment is well done.

4. It is recommended to use an electric screwdriver since many screws to tighten, be careful not to hurt your hands.



Mounting Steps

1. Assemble 1#, 2#, 3#, 4# and 5# with 24PCS M3X6 screws in the direction of the arrow.
Insert 4 screws to the bottom of the 5#, insert a screw to the 3rd hole each side, and do the same at the other 3 corners.

Note: No tightening all of the screws in this step.

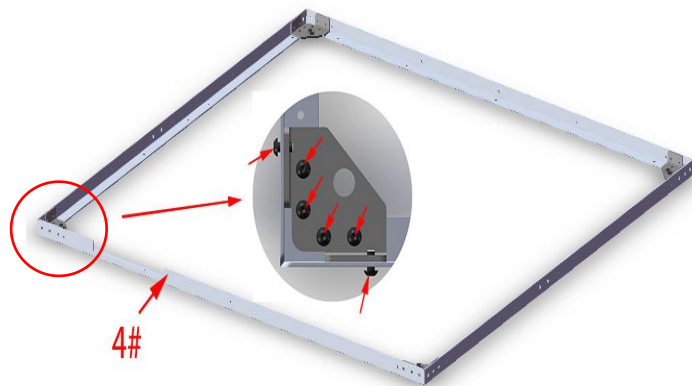
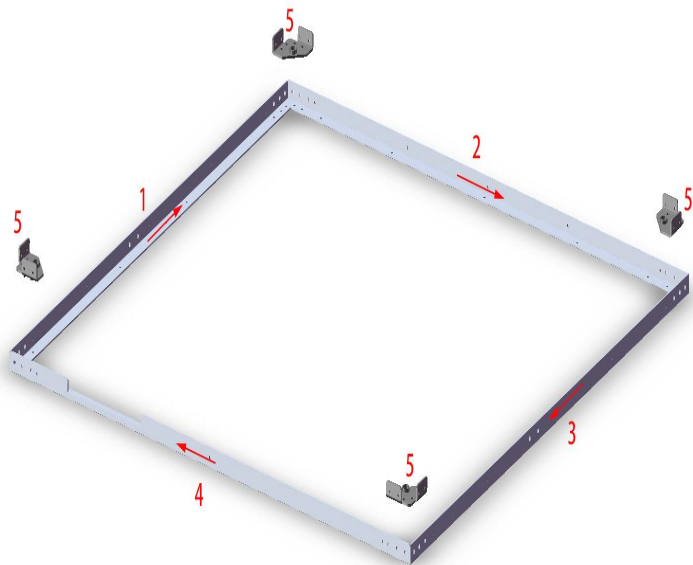

insert a screw into the 3rd hole, The other two holes are empty.

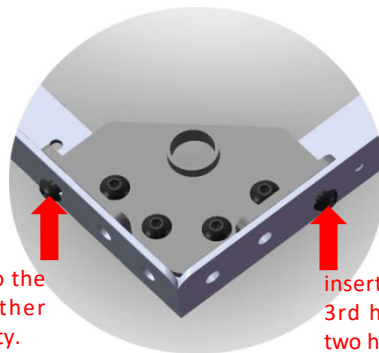

insert a screw into the 3rd hole, The other two holes are empty.

2. Assemble 6# with 9 PCS M3X6 screws, sticker face down.

Note: No tightening the screws in this step.

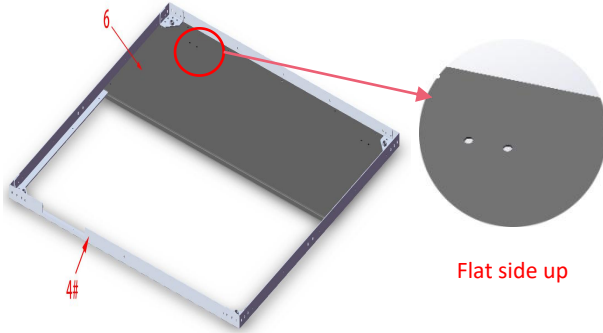

3. Assemble 7# with 11 PCS M3X6 screws, sticker face down.

Note: No tightening the screws in this step.

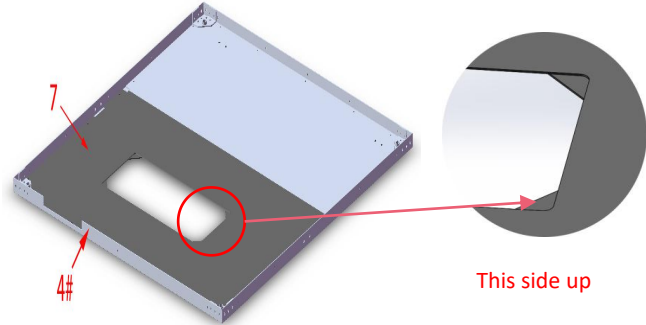

4. Assemble 8# and 9# with 4 PCS M5X14 screws.

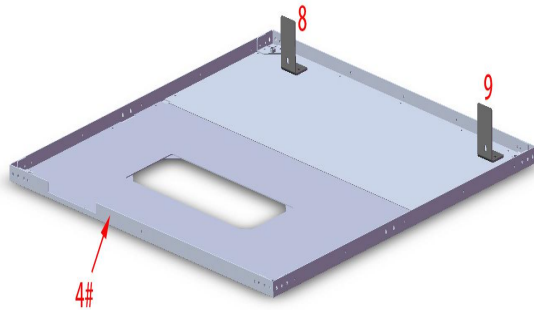

5. Assemble 10# and 11# with 4 PCS M3X6 screws in the direction of the arrow.

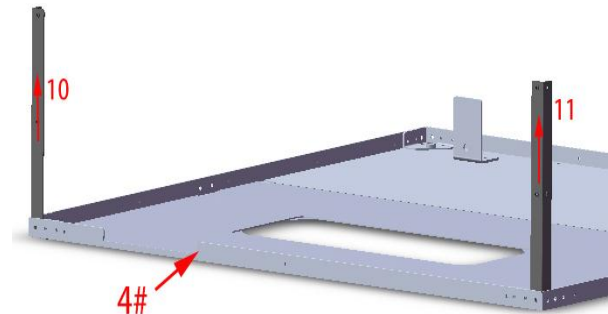

6. Assemble 12# with 4 PCS M3X6 screws in the direction of the arrow.

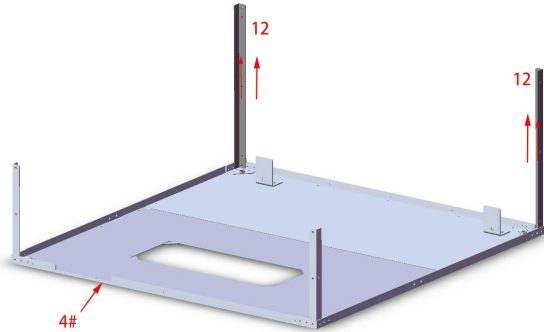

7. Assemble 13# with 4 PCS M3X6 screws in the direction of the arrow. Attention to the direction of the three M3 holes.

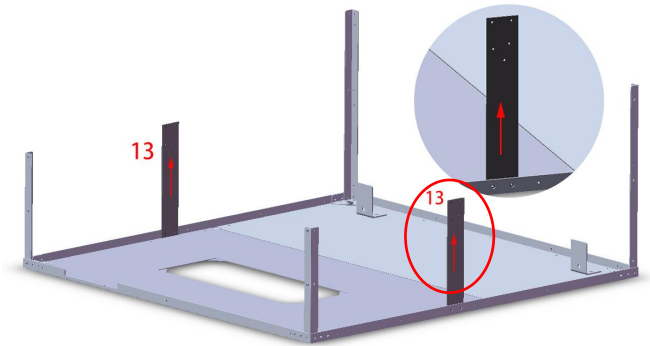

8. Assemble 14# with 18 PCS M3X6 screws in the direction of the arrow.

Note: No tightening all of the screws in this step.

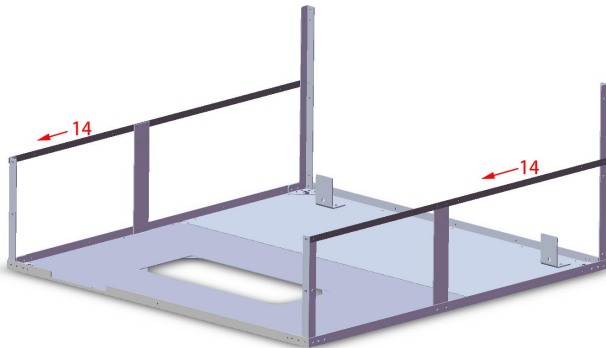

9. Ensure the nuts on the four **FOOT PADS** are at the same height and mount the **FOOT PADS**.



10. Assemble 15# with 16 PCS M3X6 screws.

Note: Please insert the diagonal 4 screws first then the other screws. Do not tighten the screws.

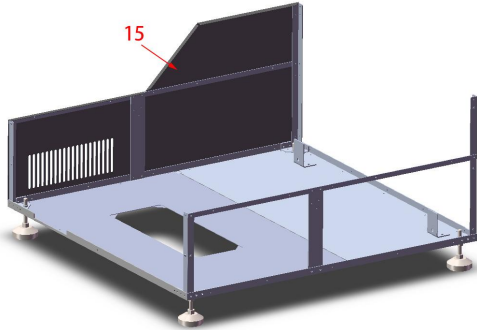

11. Assemble 16# with 16 PCS M3X6 screws.

Note: Please insert the diagonal 4 screws first then the other screws. Do not tighten the screws.

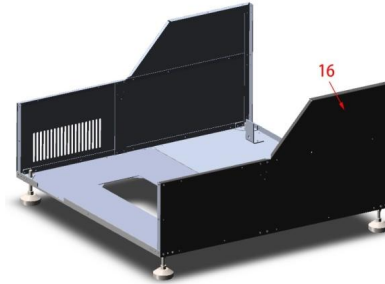

12. Tear off the adhesive of the LED strip, paste it on the back of the 17#, the positions is as shown below and fix it with cable ties and buckles.

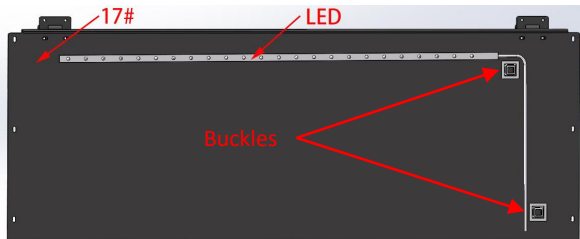

13. Assemble 17# with 6 PCS M3X6 screws.

Note: Please insert the diagonal 4 screws first then the other screws. Do not tighten the screws.

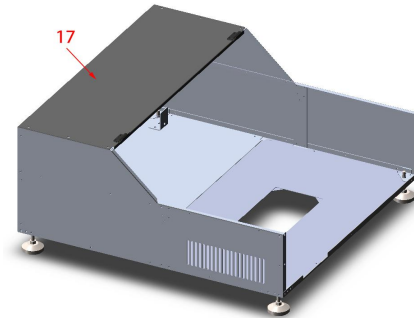

14. Assemble exhaust fan, 18# and flange.

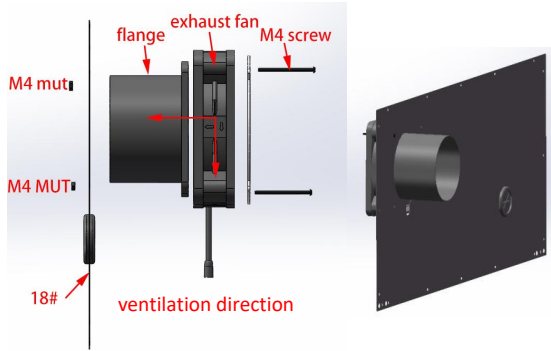

15. Assemble 18# with 18 PCS M3X6 screws.

Note: Please insert the diagonal 4 screws first then the other screws. Do not tighten the screws.

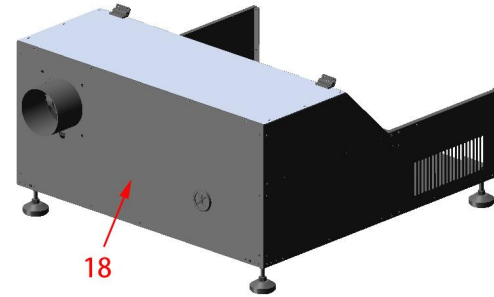

16. Assemble **ACRYLIC BOARD** to 19# with 7 PCS M4X8 screws and M4 nuts (Tear off the protective film before mounting the acrylic board)

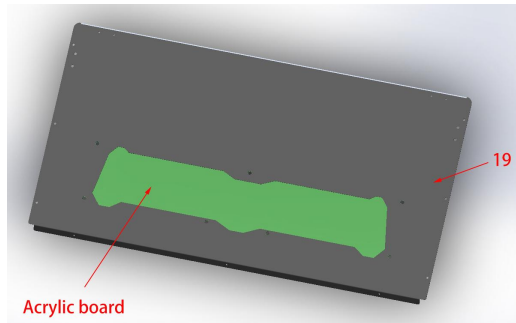

17. Assemble **ACRYLIC BOARD** to 20# with 7 PCS M4X8 screws and M4 nuts (Tear off the protective film before mounting the acrylic board)

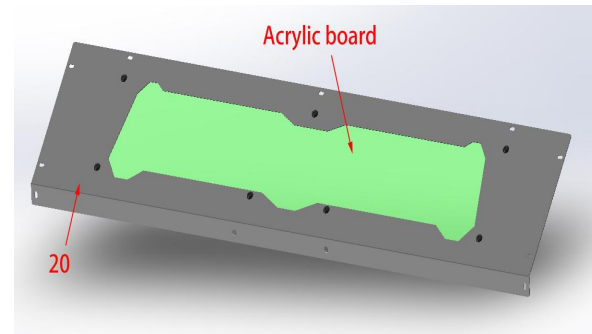

18. Assemble 19# and 20# with 3PCS M3X6 screws.

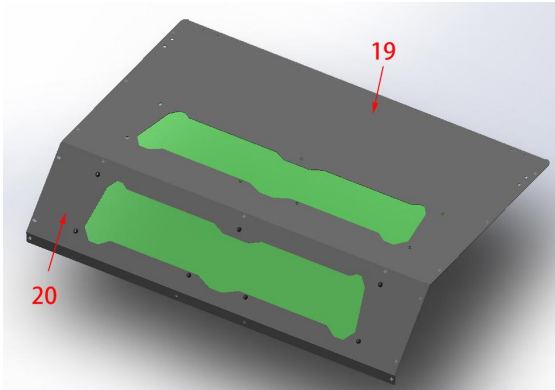

19. Assemble 21# with 6 PCS M3X6 screws.

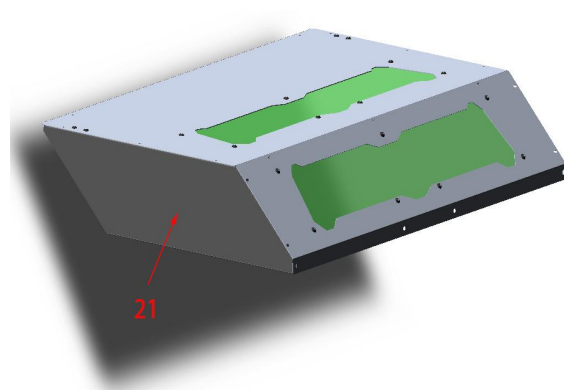

20. Assemble 22# to the upper cover with 6 PCS M3X6 screws

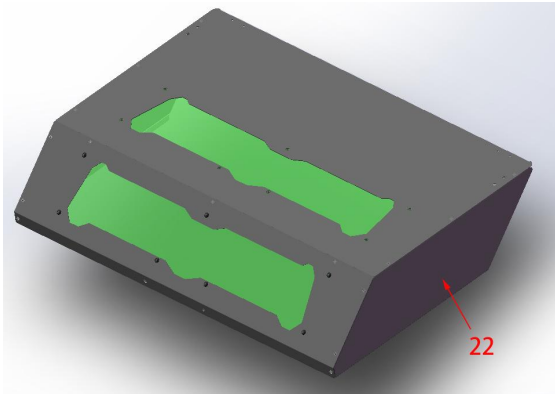

21. Assemble **SUPPORT ROD FIXING BLOCK A** to the left and right with 6 PCS M3X6 screws and gasket.

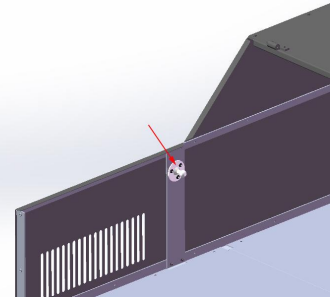
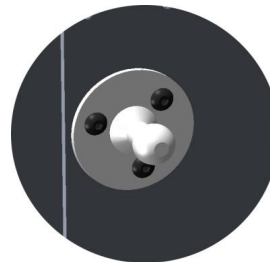

22. Mount the **SUPPORT ROD FIXING BLOCK B** to the left and right side plates of the upper cover with 4PCS M4X8 screws.

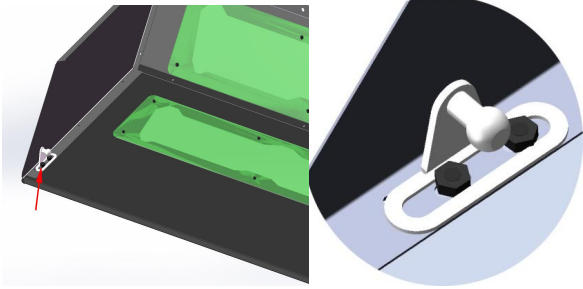

24. Well mounted the cylinder by snapping both ends of the **SUPPORT ROD** into the cylinder base.

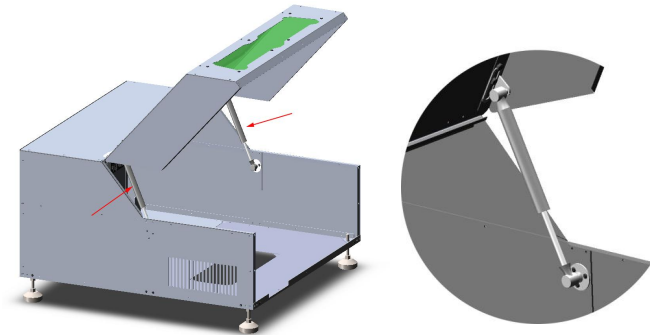

23. Mount the hinge to 19# with 4PCS M3X6 screws, then tighten the screws on the 17#.

It could be adjusted with a slight movement left and right

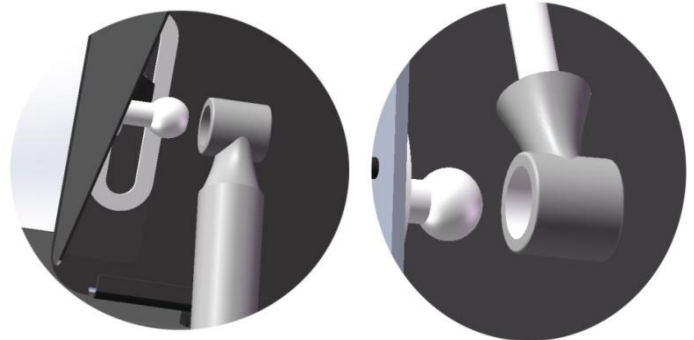
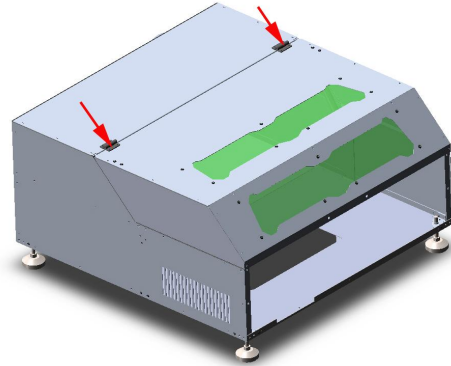

Partial enlargement

25. Put the engraver into the enclosure and fix it with 2 PCS M5X14 screws and 2PCS M5 nuts. Pay attention to the location.

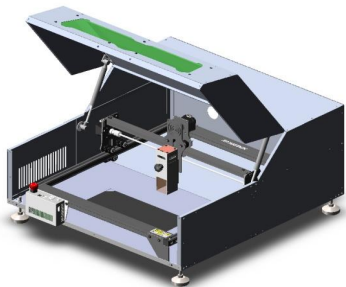

Partial enlargement

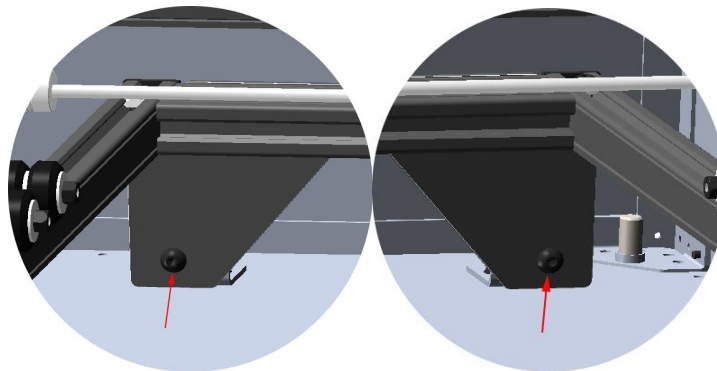

26. Mount 23# with 9 PCS M3X6 screws.

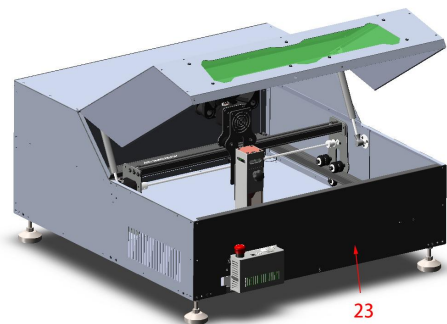

27. Put 24# on the base plate.

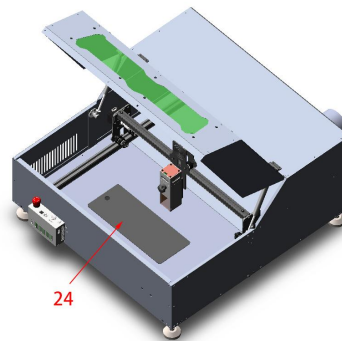

28. Connect the exhaust pipe, install the handle, and correct the deformation by adjusting the height of the foot pad. Tighten all of the screws and the installation is complete.

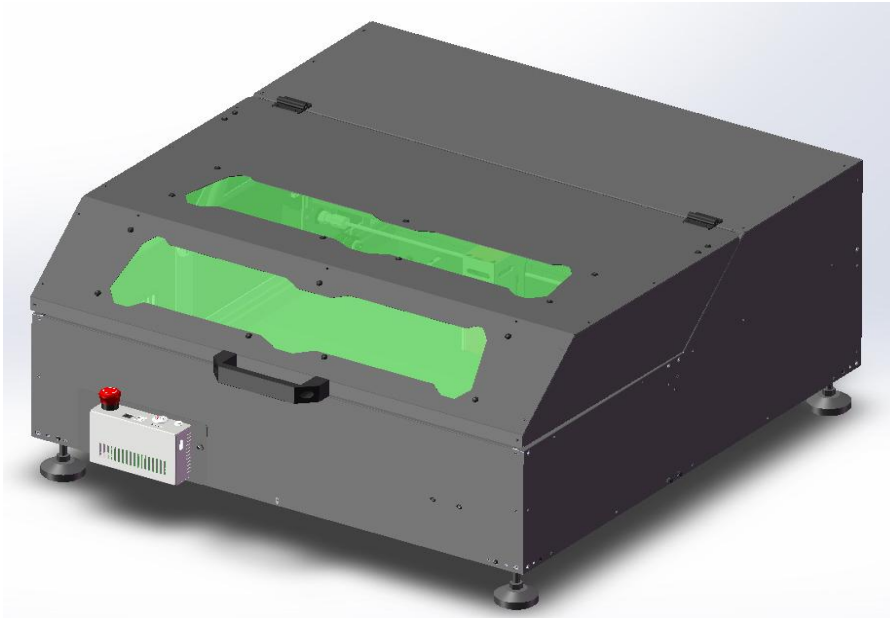



Customer Service:

➤ For detailed warranty policy, please visit our official website at: www.atomstack.com

➤ For technical support and service, please email: support@atomstack.com

Manufacturer: Shenzhen AtomStack Technologies Co., Ltd.
Address: 17th Floor, Building 3A, Phase II, Intelligent Park, No. 76,
Baohe Avenue, Baolong Street, Longgang Dist., Shenzhen, 518172,
China

Scan the code to enter the discussion group.



Scanner APPLICATION:

QR code reader/ Barcode scanner or any APP with scanner.

ATOMSTACK Staubdichtes Sicherheitsschutzgehäuse

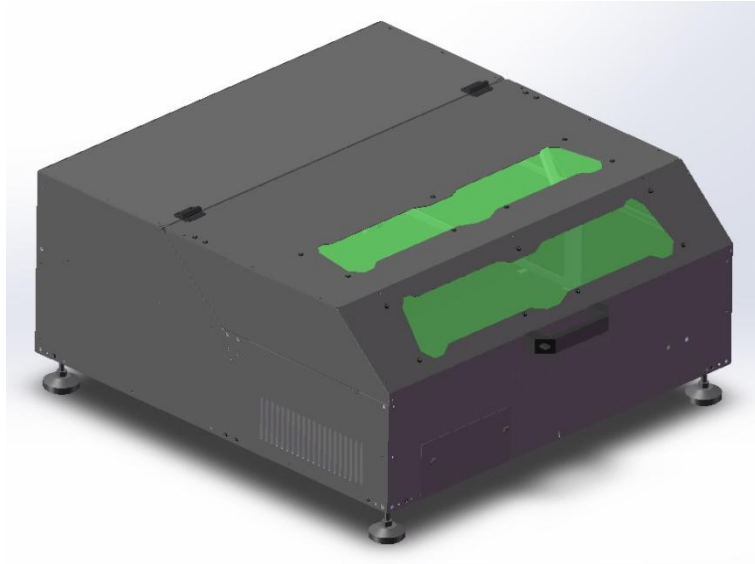

Hinweis: Das Bild dient nur als Referenz, das tatsächliche Produkt hat Vorrang.

Für das Installationsvideo-Tutorial und weitere Informationen scannen Sie bitte den QR-Code.























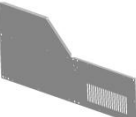

- English
- Deutsche
- Français

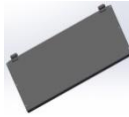

Laser Engraver

Anleitung vor der Installation:

1. Insgesamt 31 Blechteile der Schutzhülle, Details in der Tabelle. Alle Teile sind mit Seriennummernaufklebern beklebt. Zubehör: Acrylplatte 2 Stück, Fußpolster 4 Stück, Stützstange 2 Stück, Stützstangen-Befestigungsblock A 2 Stück, Stützstangen-Befestigungsblock B 2 Stück, LED-Streifen 1 Stück, Griff 1 Stück, Lüfterkomponente 1 Satz. Menge vor der Installation bestätigen.

1#	2#	3#	4#	5#	6#	7#	8#	9#
 1 Stück	 1 Stück	 1 Stück	 1 Stück	 4 Stück	 1 Stück	 1 Stück	 1 Stück	 1 Stück
10#	11#	12#	13#	14#	15#	16#	17#	18#
 1 Stück	 1 Stück	 2 Stück	 2 Stück	 2 Stück	 1 Stück	 1 Stück	 1 Stück	 1 Stück
19#	20#	21#	22#	23#	24#	25#		
 1 Stück	 1 Stück	 1 Stück	 1 Stück	 1 Stück	 1 Stück	 1 Stück		

Acrylplatte	Fußpolster	Stützstange	Stützstangen-Befestigungsblock A	Stützstangen-Befestigungsblock B	LED-Leiste	Handhaben	Abluftventilator
							
2 Stück	4 Sätze	2 Stück	2 Stück	2 Stück	1 Stück	1 Stück	1 Satz

M3*6	M3*8	M4*8 M4	M5*14 M5	M5*14 M5	M5*14 M5	M4*8 M4
						
160 Stück	10 Stück	Schrauben: 14 Stück Nuss: 14 Stück	Schrauben: 2 Stück Nuss: 2 Stück	Schrauben: 3 Stück Nuss: 1 Stück	Schrauben: 3 Stück Nuss: 1 Stück	Schrauben: 4 Stück Nuss: 4 Stück
M3*6 M3	Adaptateur d'alimentation	Adapterkabel	Schlüssel		Kabelbinder/quadratische Schnalle	
						
Schrauben: 6 Stück Waschmaschine: 6 Stück	1 Stück	1 Stück	H3 :1 Stück H2.5:1 Stück H2:2 Stück, 8# and 10#:1 Stück; 6# and 7#:1 Stück		Cable Ties: 3 Stück Square Buckle:3 Stück	

2. Das Folgende ist die ungefähre Reihenfolge der Montage.

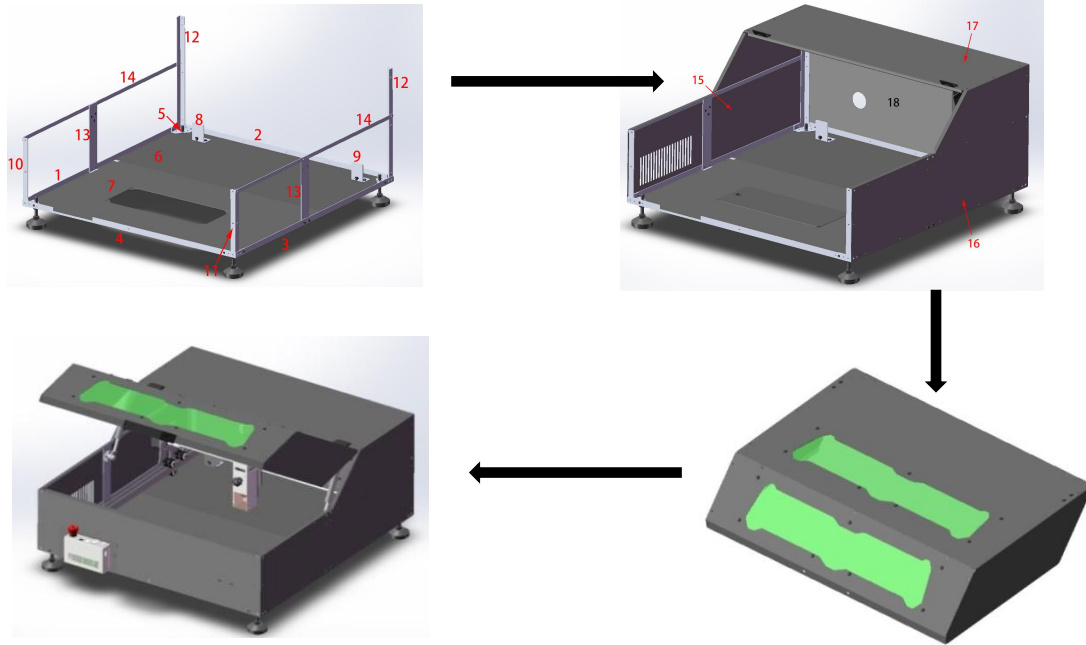

3. Ziehen Sie bei der Montage die Schrauben nicht zuerst fest. Bei der Montage einer Metallplatte können Sie zuerst die diagonalen 4 Schrauben einsetzen und dann alle Schrauben einsetzen. Ziehen Sie alle Schrauben fest, wenn die endgültige Einstellung gut durchgeführt wurde.



4. Es wird empfohlen, einen elektrischen Schraubendreher zu verwenden, da viele Schrauben festgezogen werden müssen. Achten Sie darauf, sich nicht die Hände zu verletzen.

Montageschritte

1. Montieren Sie 1#, 2#, 3#, 4# und 5# mit 24 Stück M3X6 Schrauben in Pfeilrichtung. Setzen Sie 4 Schrauben an der Unterseite des 5# ein, setzen Sie eine Schraube in das 3. Loch auf jeder Seite ein und machen Sie dasselbe an den anderen 3 Ecken.

Hinweis: Ziehen Sie in diesem Schritt nicht alle Schrauben fest.

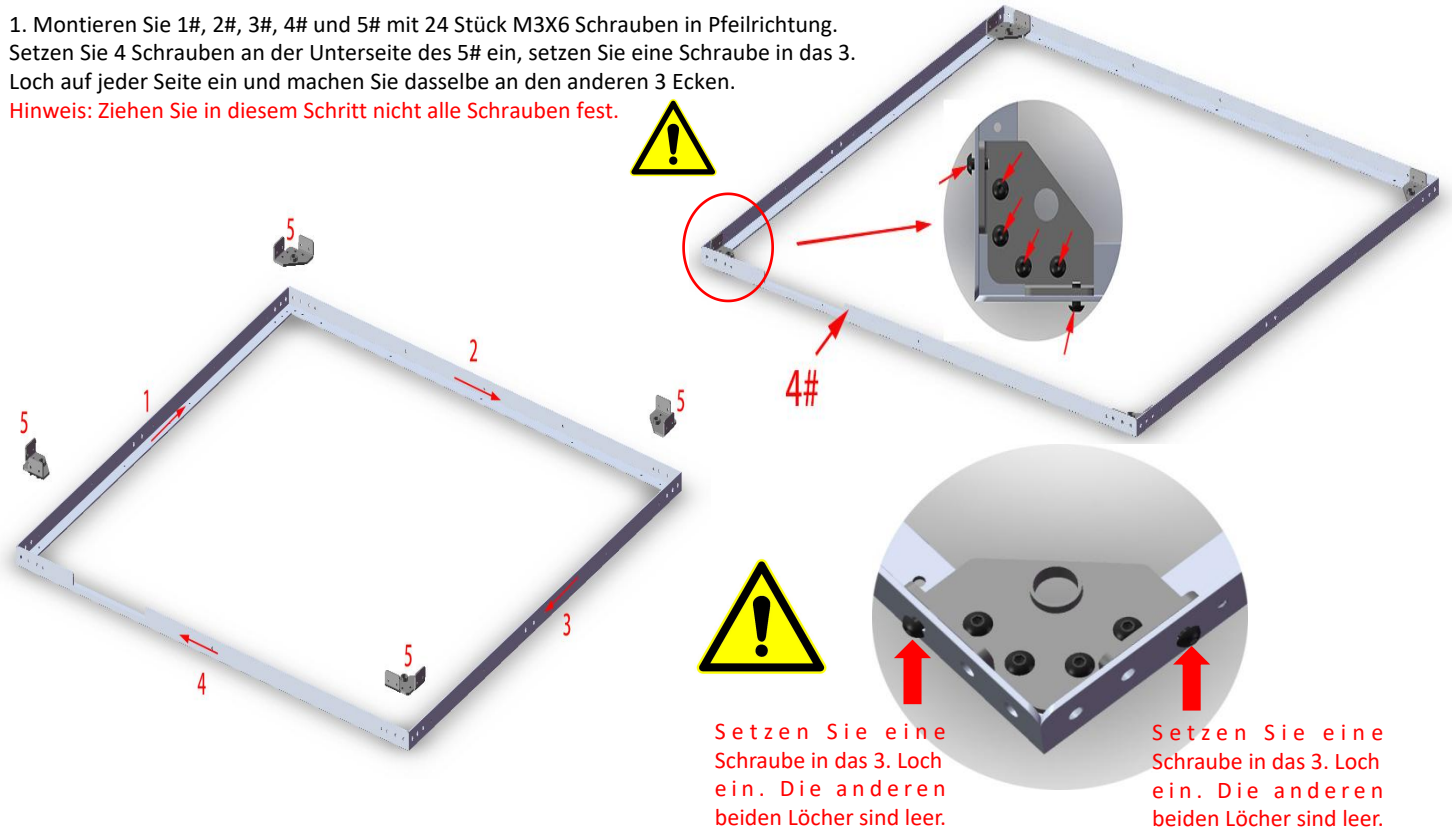

2. Montieren Sie 6 # mit 9 Stück M3X6 Schrauben, Aufkleber nach unten.

Hinweis: Die Schrauben in diesem Schritt nicht festziehen.

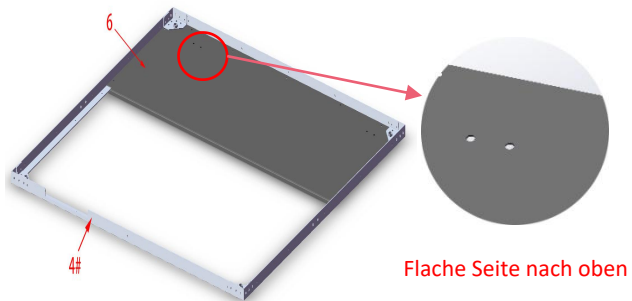

Flache Seite nach oben

3. Montieren Sie 7 # mit 11 Stück M3X6 Schrauben, Aufkleber nach unten.

Hinweis: Die Schrauben in diesem Schritt nicht festziehen.

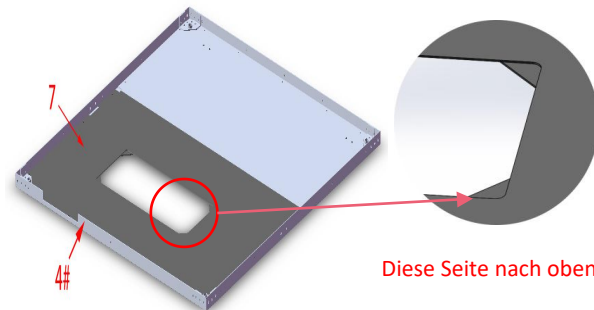

Diese Seite nach oben

4. Montieren Sie 8# und 9# mit 4 Stück M5X14 Schrauben.

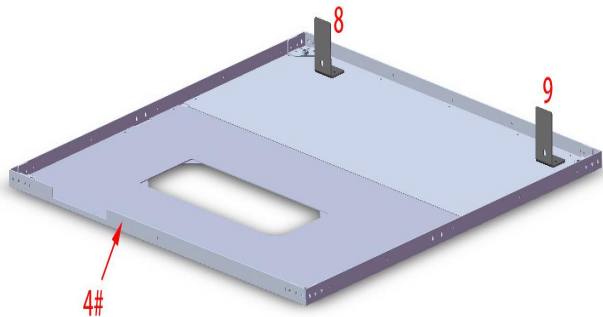

5. Montieren Sie 10# und 11# mit 4 Stück M3X6 Schrauben in Pfeilrichtung.

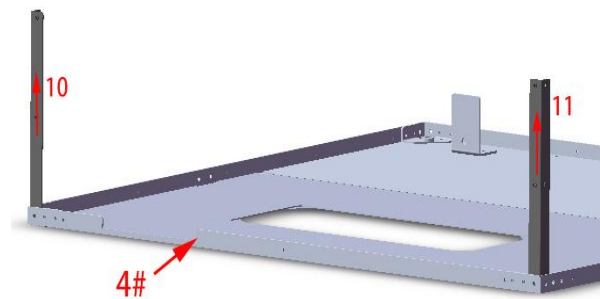

6. Montieren Sie 12 # mit 4 Stück M3X6 Schrauben in Pfeilrichtung.

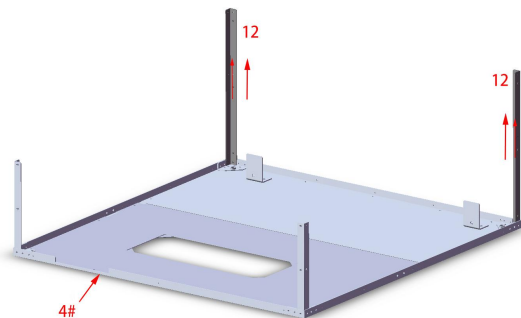

7. Montieren Sie 13 # mit 4 PCS M3X6 Schrauben in Pfeilrichtung. Achten Sie auf die Richtung der drei M3-Löcher.

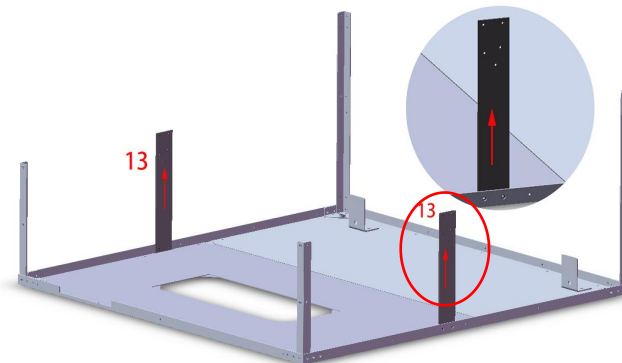

8. Montieren Sie 14 # mit 18 Stück M3X6 Schrauben in Pfeilrichtung.

Hinweis: Ziehen Sie in diesem Schritt nicht alle Schrauben fest.

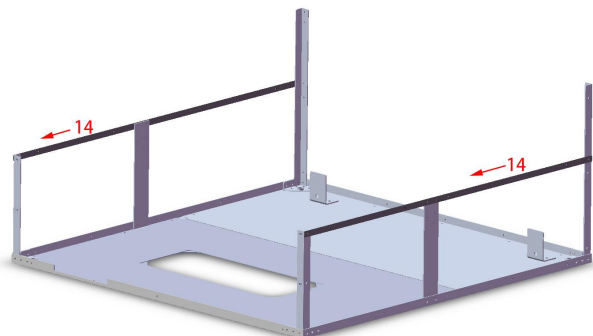

9. Stellen Sie sicher, dass sich die Muttern an den vier FUSSPOLSTERN auf gleicher Höhe befinden und montieren Sie die FUSSPOLSTER.



10. Montieren Sie 15 # mit 16 Stück M3X6 Schrauben.

Hinweis: Setzen Sie zuerst die 4 diagonalen Schrauben und dann die anderen Schrauben ein. Ziehen Sie die Schrauben nicht fest.

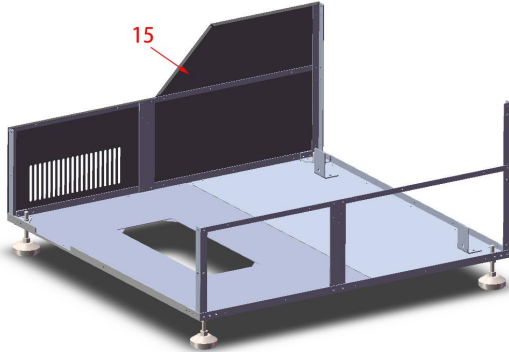

11. Montieren Sie 16 # mit 16 Stück M3X6 Schrauben.

Hinweis: Setzen Sie zuerst die 4 diagonalen Schrauben und dann die anderen Schrauben ein. Ziehen Sie die Schrauben nicht fest.

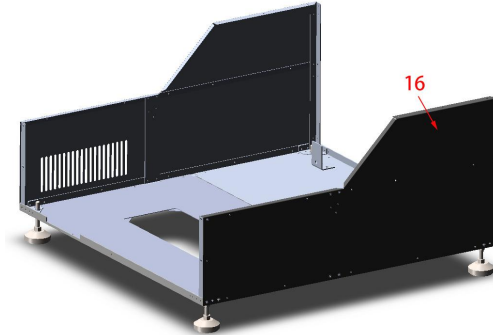

12. Reißen Sie den Kleber des LED-Streifens ab, kleben Sie ihn auf die Rückseite des 17#, die Positionen sind wie unten gezeigt und befestigen Sie ihn mit Kabelbindern und Schnallen.



13. Montieren Sie 17 # mit 6 Stück M3X6 Schrauben.

Hinweis: Setzen Sie zuerst die 4 diagonalen Schrauben und dann die anderen Schrauben ein. Ziehen Sie die Schrauben nicht fest.

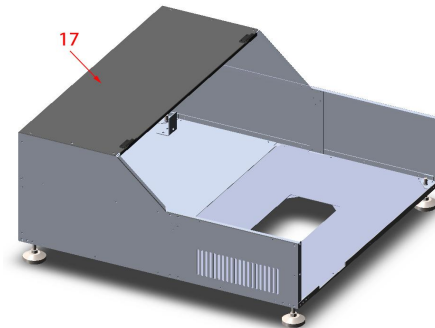
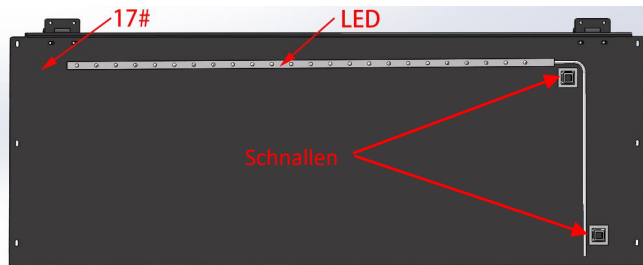

14. Montieren Sie den Abluftventilator, 18# und den Flansch.

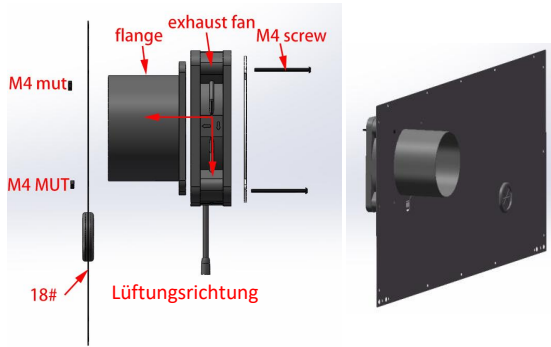

16. Montieren Sie ACRYLIC BOARD auf 19 # mit 7 Stück M4X8-Schrauben und M4-Muttern (Ziehen Sie die Schutzfolie ab, bevor Sie die Acrylplatte montieren).

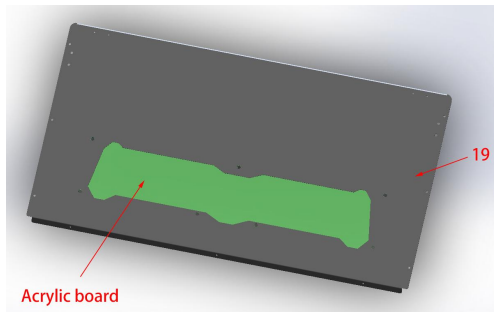

15. Montieren Sie 18 # mit 18 Stück M3X6 Schrauben.

Hinweis: Setzen Sie zuerst die 4 diagonalen Schrauben und dann die anderen Schrauben ein. Ziehen Sie die Schrauben nicht fest.

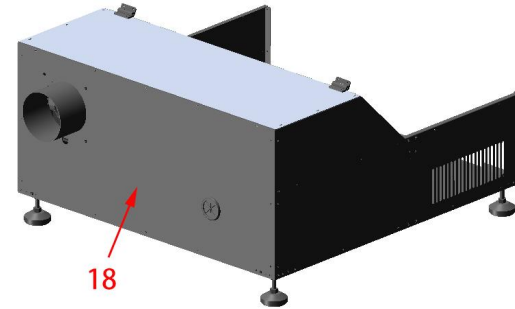

17. Montieren Sie ACRYLIC BOARD auf 20 # mit 7 Stück M4X8-Schrauben und M4-Muttern (Ziehen Sie die Schutzfolie ab, bevor Sie die Acrylplatte montieren).

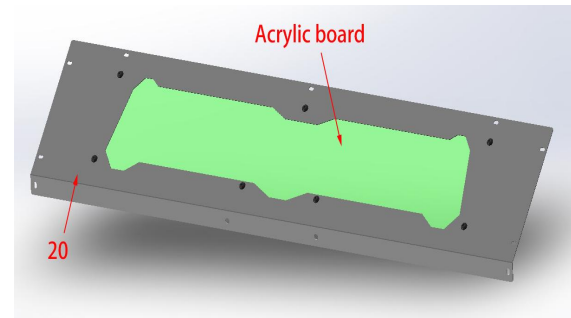

18. Montieren Sie 19# und 20# mit 3 Stück M3X6 Schrauben.

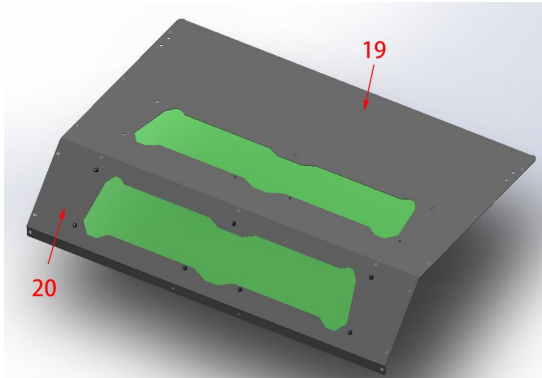

19. Montieren Sie 21 # mit 6 Stück M3X6 Schrauben.

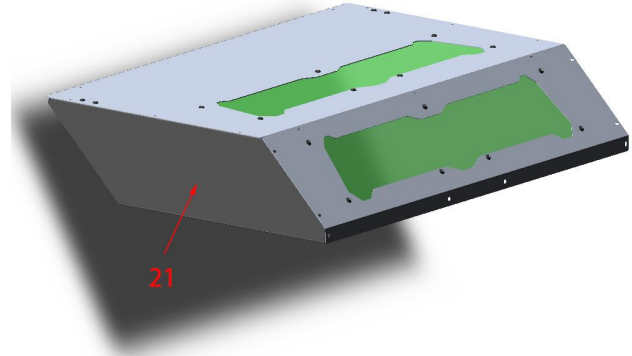

20. Montieren Sie #22 mit 6 Stück M3X6-Schrauben an der oberen Abdeckung.

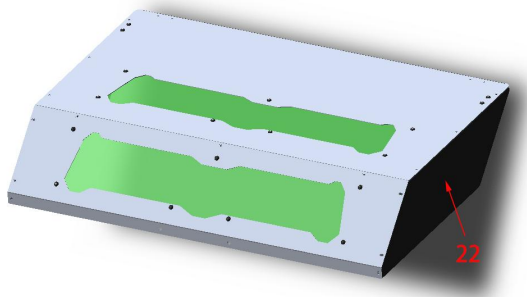

21. Montieren Sie den STÜTZSTANGEN-BEFESTIGUNGSBLOCK A links und rechts mit 6 Stück Schrauben M3X6 und flaches pad.

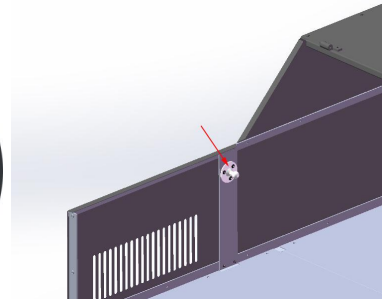
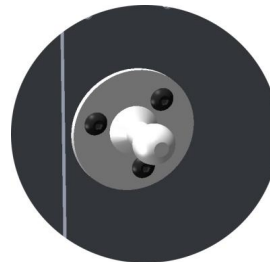

22. Montieren Sie den STÜTZSTANGEN-BEFESTIGUNGSBLOCK B an der linken und rechten Seitenplatte der oberen Abdeckung mit 4 STÜCK M4X8-Schrauben.

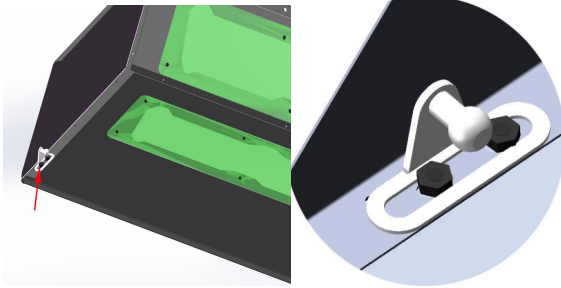

24. Montieren Sie den Zylinder gut, indem Sie beide Enden der STÜTZSTANGE in die Zylinderbasis einrasten lassen.

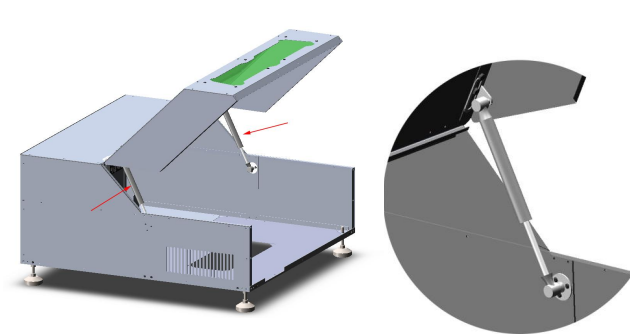

23. Montieren Sie das Scharnier mit 4 Stück M3X6-Schrauben an #19 und ziehen Sie dann die Schrauben an #17 fest..

Es konnte mit einer leichten Bewegung nach links und rechts verstellt werden.

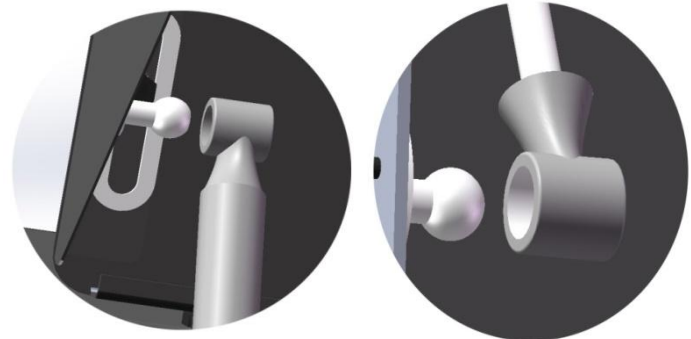
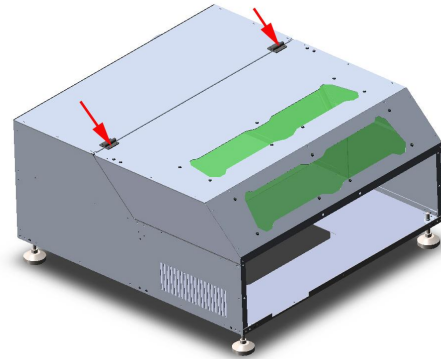

Teilweise Vergrößerung

25. Setzen Sie den Graveur in das Gehäuse ein und befestigen Sie ihn mit 2 Stück M5X14-Schrauben und 2 Stück M5-Muttern. Achten Sie auf die Position.

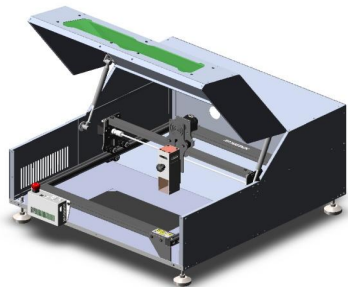

Teilweise Vergrößerung

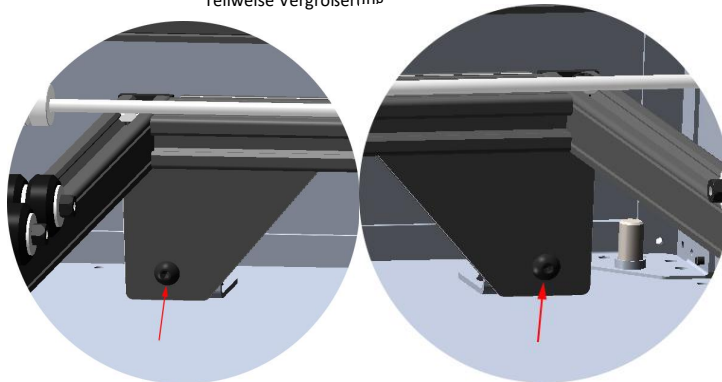

26. Montieren Sie 23# mit 9 Stück M3X6 Schrauben.

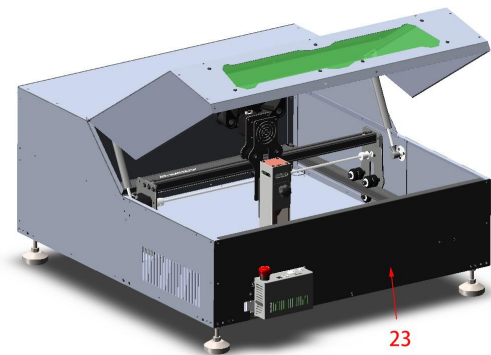

27. Setzen Sie 24 # auf die Grundplatte.

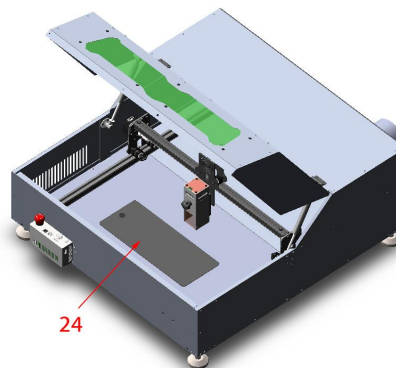

28. Schließen Sie das Auspuffrohr an, installieren Sie den Griff und korrigieren Sie die Verformung, indem Sie die Höhe des Fußpolsters anpassen. Ziehen Sie alle Schrauben fest und die Installation ist abgeschlossen.

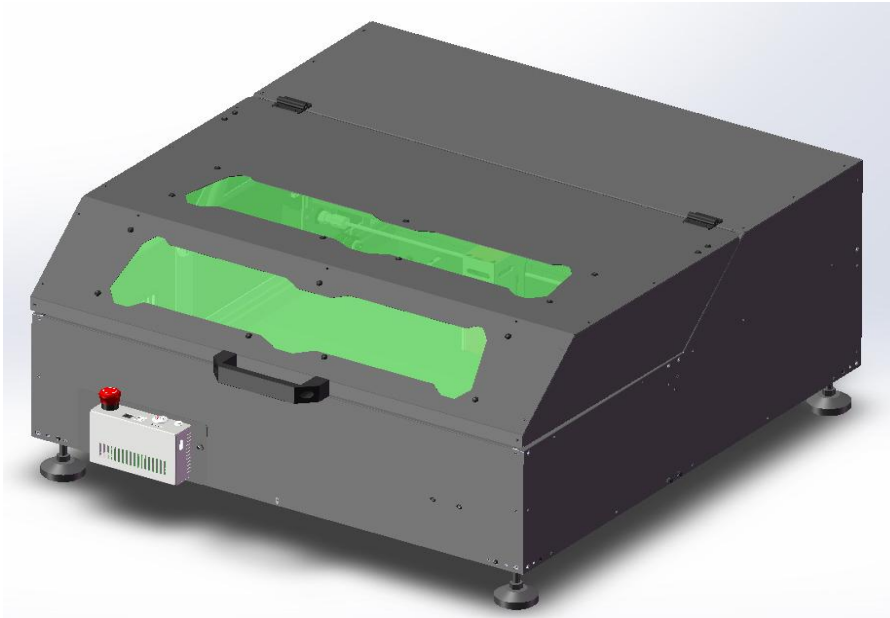



Kundendienst :

➤ Für detaillierte Garantiebestimmungen besuchen Sie bitte unsere offizielle Website unter : www.atomstack.com

➤ Für technischen Support und Service senden Sie bitte eine E-Mail : support@atomstack.com

Hersteller: Shenzhen AtomStack Technologies Co., Ltd.Adresse: 17. Stock, Gebäude 3A, Phase II, Intelligent Park, Nr. 76, Baohe Avenue, Baolong Street, Longgang Dist., Shenzhen, 518172, China

Scannen Sie den Code, um die Diskussionsgruppe zu betreten.



Scanner ANWENDUNG:
QR-Code-Leser / Barcode-Scanner oder jede APP mit Scanner.

Boîtier de protection de sécurité anti-poussière ATOMSTACK

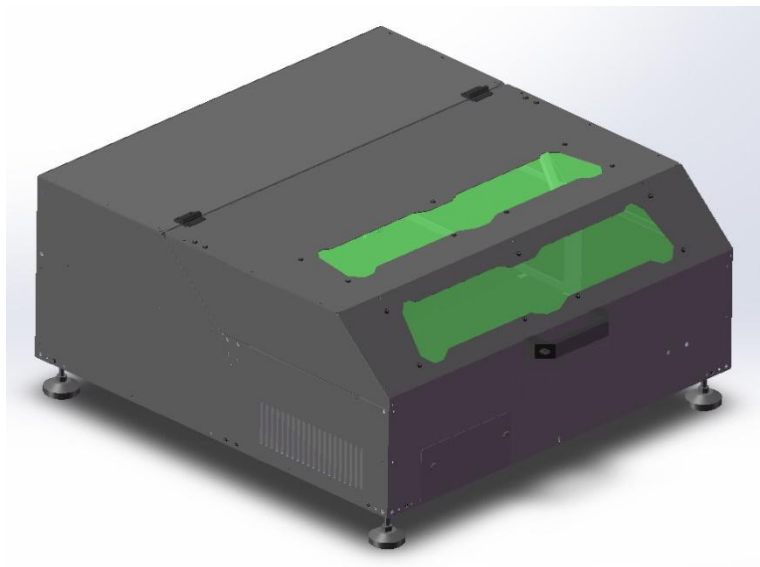

Remarque : l'image est fournie à titre indicatif uniquement, le produit réel prévaudra.

Pour le tutoriel vidéo d'installation et d'autres informations, veuillez scanner le code QR.























- English
- Deutsche
- Français

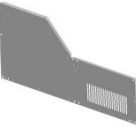

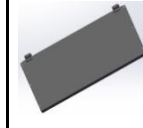
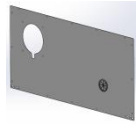





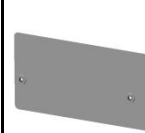

Laser Engraver

Pinstructions de réinstallation:

1. Total 31 composants en tôle du capot de protection, détails dans le tableau. Toutes les pièces sont collées avec des autocollants de numéro de série. Accessoires : panneau acrylique 2 pièces, repose-pieds 4 pièces, tige de support 2 pièces, bloc de fixation de tige de support A 2 pièces, bloc de fixation de tige de support B 2 pièces, bande LED 1 pièce, poignée 1 pièce, composant de ventilateur 1 jeu. Confirmer la quantité avant l'installation.

1#	2#	3#	4#	5#	6#	7#	8#	9#
 1 pièce	 1 pièce	 1 pièce	 1 pièce	 4 pièces	 1 pièce	 1 pièce	 1 pièce	 1 pièce
10#	11#	12#	13#	14#	15#	16#	17#	18#
 1 pièce	 1 pièce	 2 pièces	 2 pièces	 2 pièces	 1 pièce	 1 pièce	 1 pièce	 1 pièce
19#	20#	21#	22#	23#	24#	25#		
 1 pièce	 1 pièce	 1 pièce	 1 pièce	 1 pièce	 1 pièce	 1 pièce		

Panneau acrylique	Coussinet de pied	Tige de soutien	Bloc de fixation de tige de support A	Bloc de fixation de tige de support B	Bande LED	Gérer	Ventilateur d'extraction
							
2 pièces	4 ensembles	2 pièces	2 pièces	2 pièces	1 pièce	1 pièce	1 jeu

M3*6	M3*8	M4*8 M4	M5*14 M5	M5*14 M5	M5*14 M5	M4*8 M4
						
160 pièces	10 pièces	Des vis: 14 pièces Noix: 14 pièces	Des vis: 2 pièces Noix: 2 pièces	Des vis: 3 pièces Noix: 1 pièces	Des vis: 3 pièces Noix: 1 pièces	Des vis: 4 pièces Noix: 4 pièces
M3*6 M3	Câble d'alimentation	Câble adaptateur	Clé		Attaches de câble/boucle carrée	
						
Des vis: 6 pièces joint d'étanchéité: 6 pièces	1 pièces	1 pièces	H3 : 1 pièces H2.5: 1 pièces H2: 2pièces, 8# and 10#: 1pièces; 6# and 7#: 1pièces		Cable Ties: 3pièces Square Buckle: 3pièces	

2. Voici la séquence approximative d'assemblage.

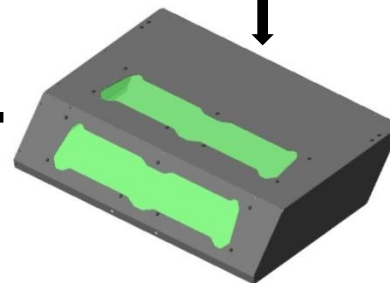
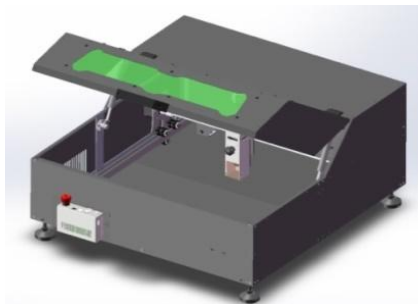
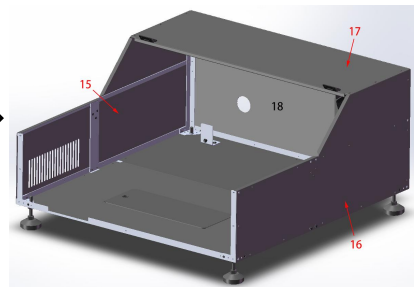
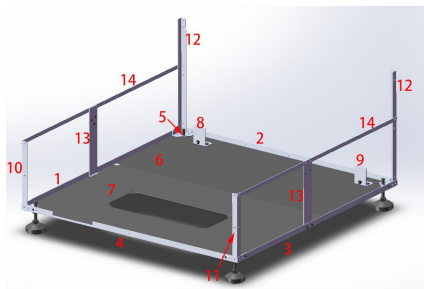

3. Lors du montage, ne serrez pas les vis en premier. Vous pouvez d'abord insérer les 4 vis diagonales lors du montage d'une plaque métallique, puis insérer toutes les vis. Resserrer toutes les vis lorsque le réglage final est bien fait.



4. Il est recommandé d'utiliser un tournevis électrique car beaucoup de vis à serrer, attention à ne pas se faire mal aux mains.

Étapes de montage

1. Assemblez 1#, 2#, 3#, 4# et 5# avec 24 vis M3X6 dans le sens de la flèche. Insérez 4 vis au bas du 5 #, insérez une vis dans le 3e trou de chaque côté et faites de même aux 3 autres coins.

Remarque : ne serrez pas toutes les vis à cette étape.

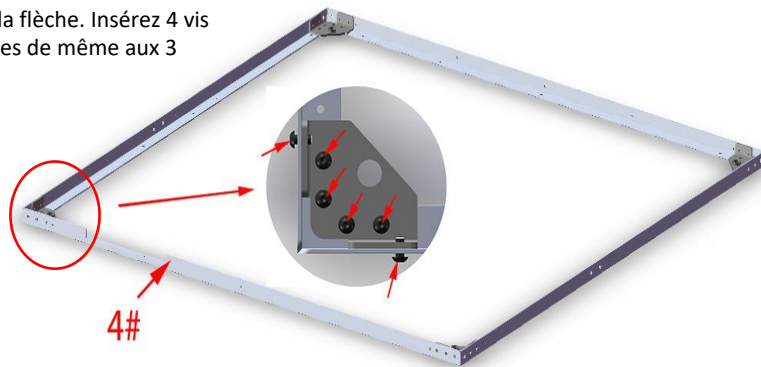
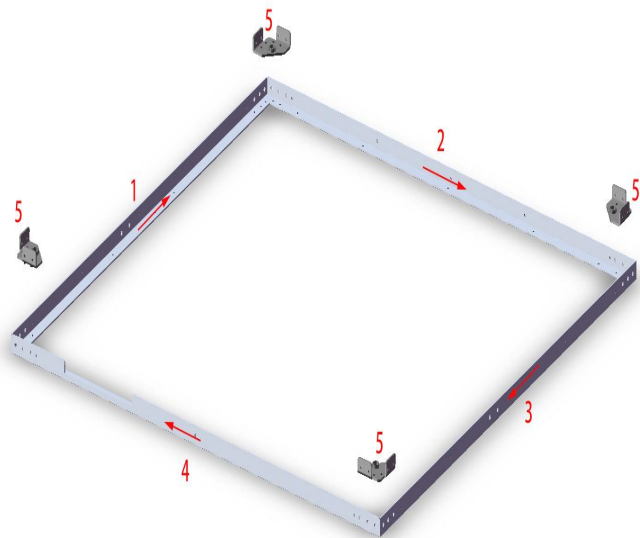

insérez une vis dans le 3ème trou, les deux autres trous sont vides.

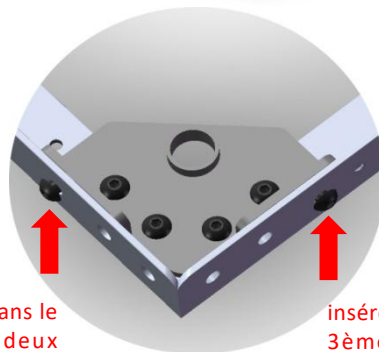

insérez une vis dans le 3ème trou, les deux autres trous sont vides.

2. Assemblez 6 # avec 9 vis M3X6, autocollant face vers le bas.

Remarque : Ne serrez pas les vis à cette étape.

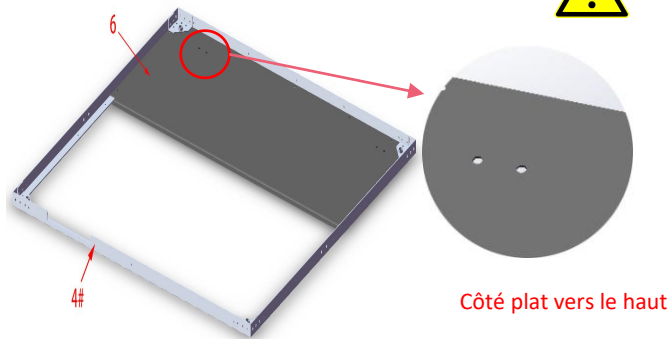

3. Assemblez 7 # avec 11 vis M3X6, autocollant face vers le bas.

Remarque : Ne serrez pas les vis à cette étape.

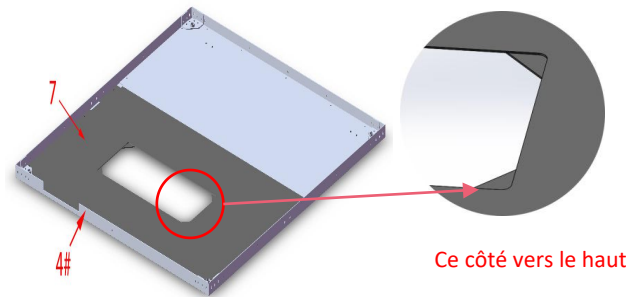

4. Assemblez 8 # et 9 # avec 4 vis M5X14.

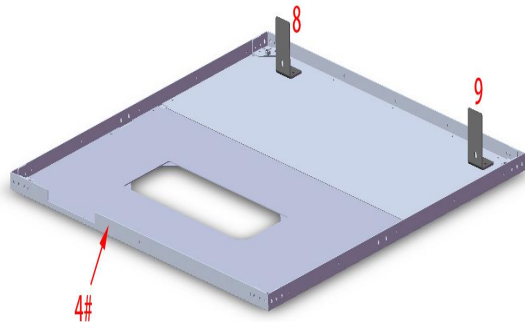

5. Assemblez 10# et 11# avec 4 vis M3X6 dans le sens de la flèche.

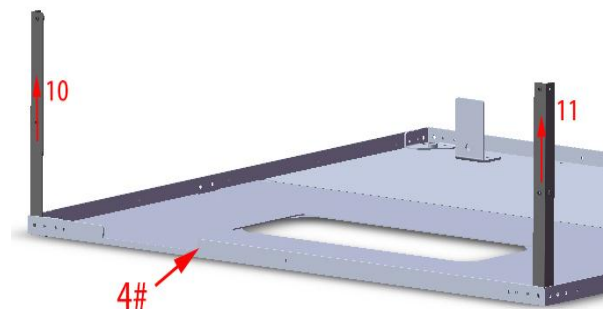

6. Assemblez 12 # avec 4 vis M3X6 dans le sens de la flèche.

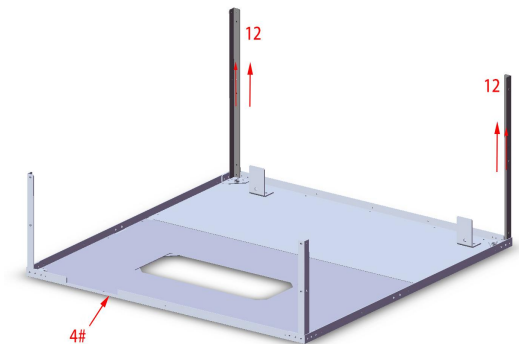

7. Assemblez 13 # avec 4 vis PCS M3X6 dans le sens de la flèche. Attention au sens des trois trous M3.

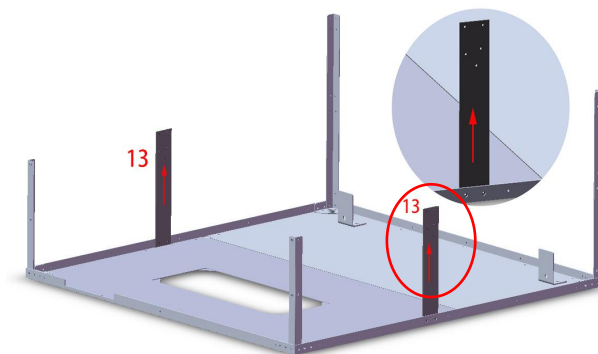

8. Assemblez 14 # avec 18 vis M3X6 dans le sens de la flèche.

Remarque : ne serrez pas toutes les vis à cette étape.

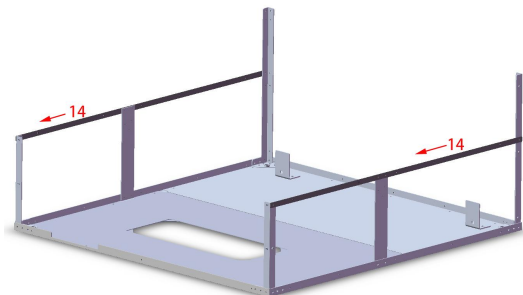

9. Assurez-vous que les écrous des quatre PATINS DE PIED sont à la même hauteur et montez les PATINS DE PIED.



10. Assemblez 15 # avec 16 vis M3X6.

Remarque : veuillez d'abord insérer les 4 vis diagonales, puis les autres vis. Ne serrez pas les vis.

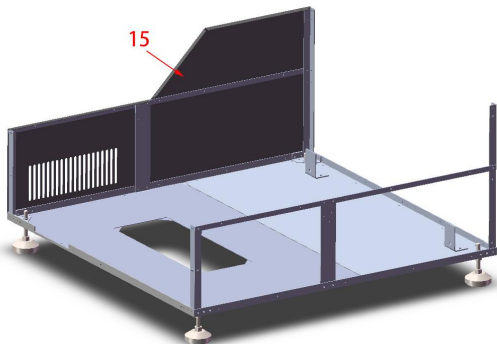

11. Assemblez 16 # avec 16 vis M3X6.

Remarque : veuillez d'abord insérer les 4 vis diagonales, puis les autres vis. Ne serrez pas les vis.

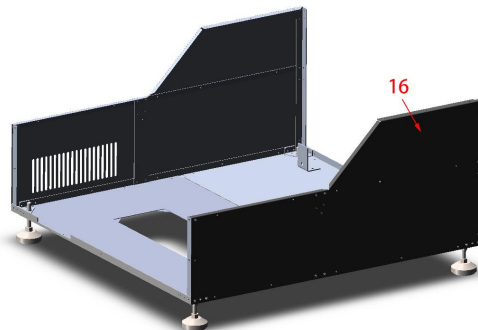

12. Détachez l'adhésif de la bande LED, collez-le à l'arrière du 17 #, les positions sont comme indiqué ci-dessous et fixez-le avec des attaches de câble et des boucles.

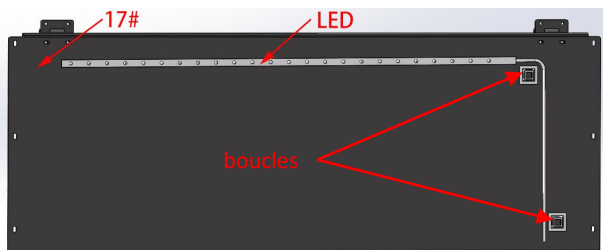

13. Assemblez 17 # avec 6 vis M3X6.

Remarque : veuillez d'abord insérer les 4 vis diagonales, puis les autres vis. Ne serrez pas les vis.

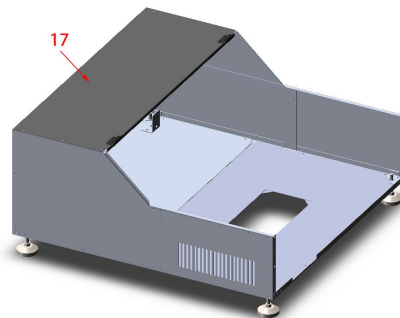

14. Assemblez le ventilateur d'extraction, 18 # et la bride.

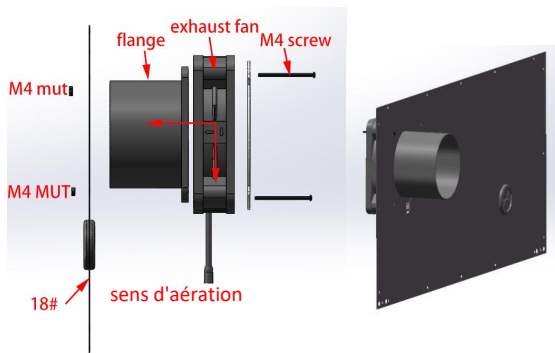

16. Assemblez le PANNEAU ACRYLIQUE à 19 # avec 7 vis M4X8 et écrous M4 (Déchirez le film protecteur avant de monter le panneau acrylique)

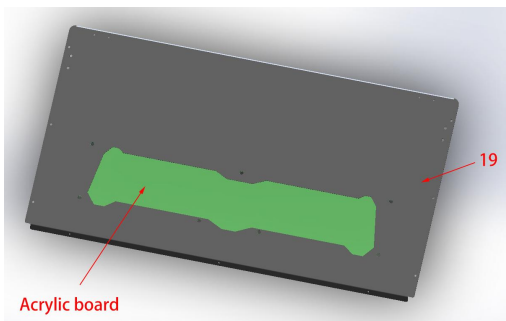

15. Assemblez 18 # avec 18 vis PCS M3X6.

Remarque : veuillez d'abord insérer les 4 vis diagonales, puis les autres vis. Ne serrez pas les vis.

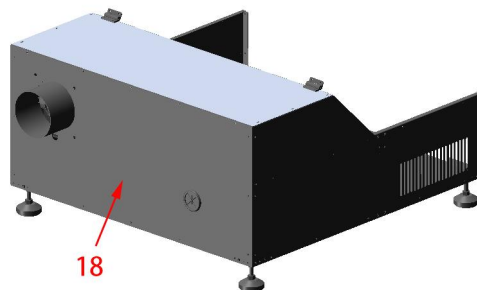

17. Assemblez le PANNEAU ACRYLIQUE à 20# avec 7 vis M4X8 et écrous M4 (Déchirez le film protecteur avant de monter le panneau acrylique)

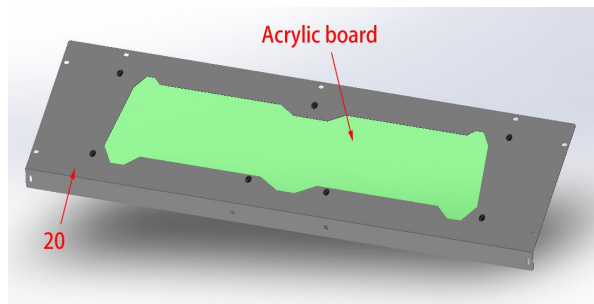

18. Assemblez 19 # et 20 # avec 3 vis M3X6.

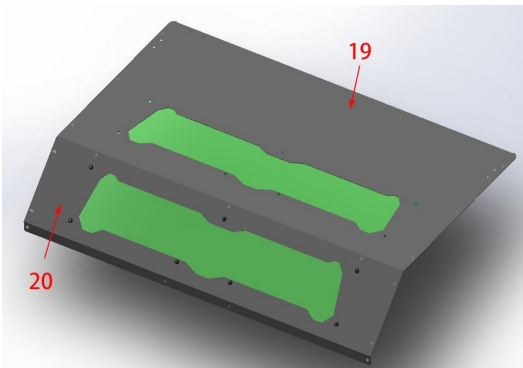

19. Assemblez 21 # avec 6 vis M3X6.

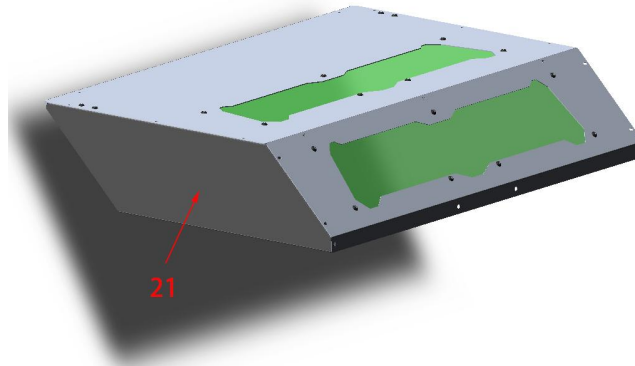

20. Assemblez 22 # au couvercle supérieur avec 6 vis M3X6.

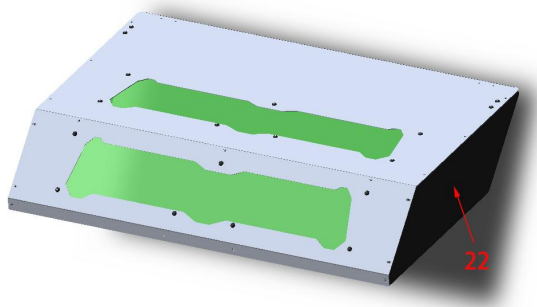

21. Assemblez le BLOC DE FIXATION DE LA TIGE DE SUPPORT A à gauche et à droite avec 6 vis M3X6 et Tampon plat.

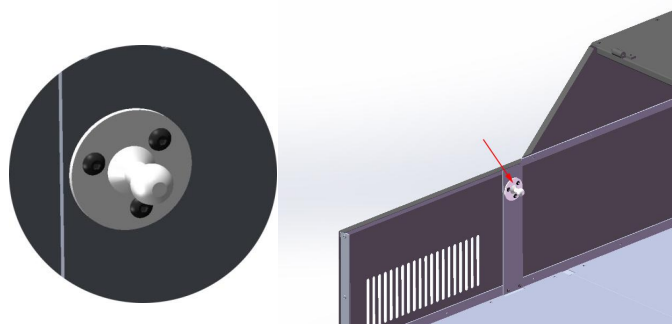

22. Montez le BLOC DE FIXATION DE LA TIGE DE SUPPORT B sur les plaques latérales gauche et droite du capot supérieur avec 4 vis M4X8..

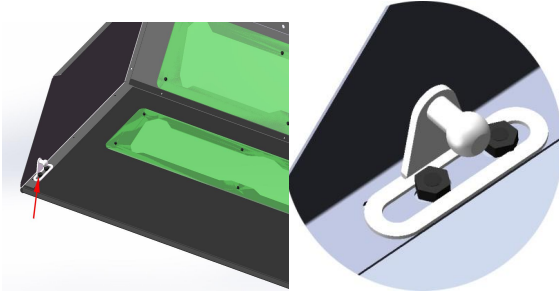

24. Bien monter le cylindre en enclenchant les deux extrémités de la TIGE DE SUPPORT dans la base du cylindre.

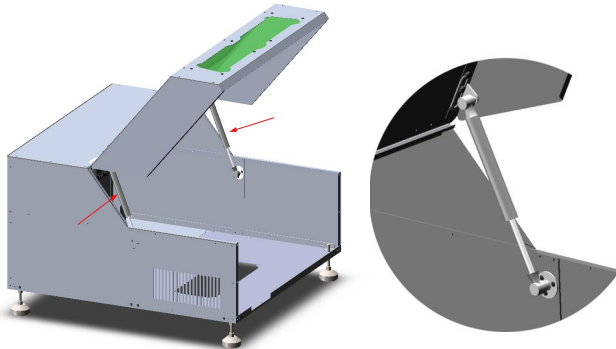

23. Montez la charnière sur 19 # avec 4 vis M3X6, puis serrez les vis sur le 17 #.

Il peut être ajusté avec un léger mouvement à gauche et à droite.

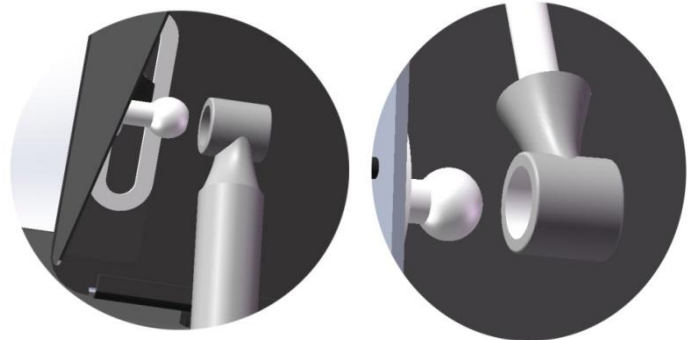
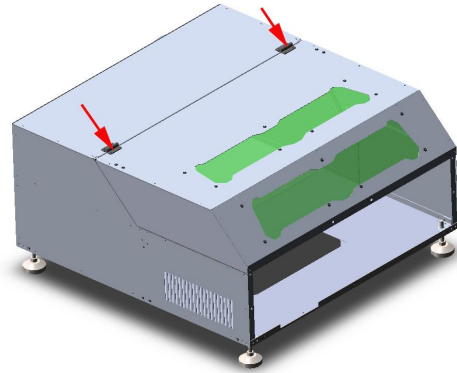

Agrandissement partiel

25. Placez le graveur dans le boîtier et fixez-le avec 2 vis PCS M5X14 et 2 écrous PCS M5. Faites attention à l'emplacement.

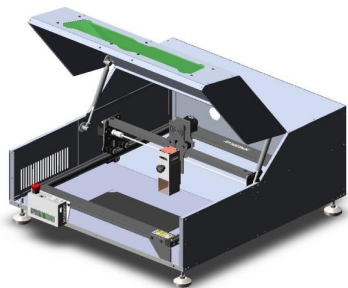

Agrandissement partiel

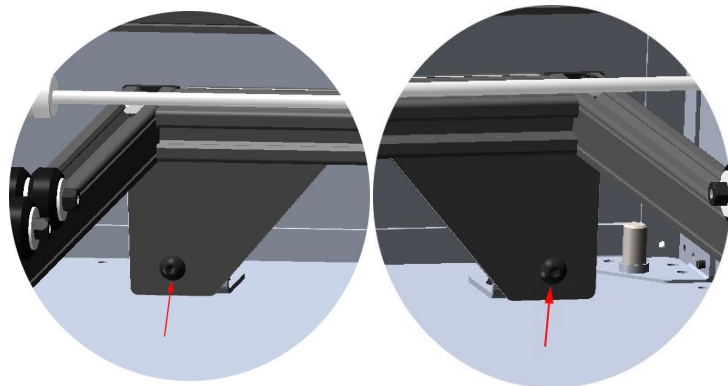

26. Montez 23 # avec 9 vis M3X6.

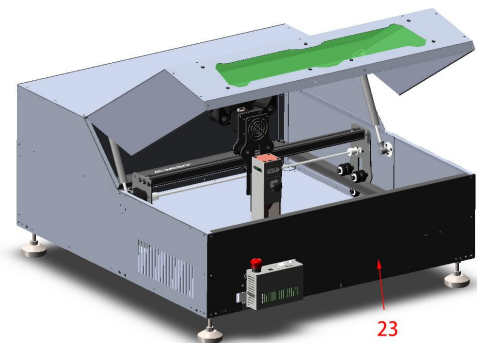

27. Mettez 24 # sur la plaque de base.

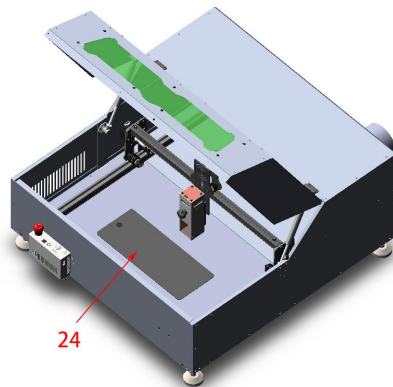

28. Connectez le tuyau d'échappement, installez la poignée et corrigez la déformation en ajustant la hauteur du repose-pieds. Serrez toutes les vis et l'installation est terminée.

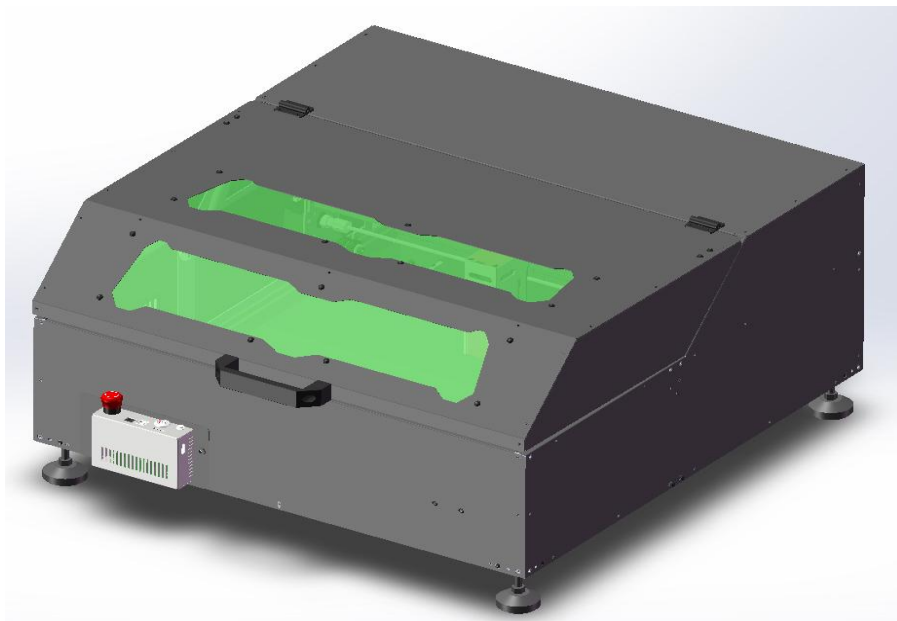



Service Clients :

➤ Pour une politique de garantie détaillée, veuillez visiter notre site Web officiel à l'adresse: www.atomstack.com

➤ Pour une politique de garantie détaillée, veuillez visiter notre site Web officiel à l'adresse: support@atomstack.com

Fabricant: Shenzhen AtomStack Technologies Co., Ltd. Adresse : 17e étage, bâtiment 3A, phase II, parc intelligent, n° 76, avenue Baohe, rue Baolong, district Longgang, Shenzhen, 518172, Chine

Scannez le code pour entrer dans le groupe de discussion.



APPLICATIONS du scanner :
Lecteur de code QR/scanner de code-barres ou toute application avec scanner.